

Dear readers,

the ASTECH team is pleased to present the second edition of the *Sensitive* in 2016.

This edition presents two new members of the VLM series, the VLM502 and VLM500E. The non-contact measurement of speed and length device VLM has been an integral part of the ASTECH product portfolio for the last decades.

The main focus of this edition is the VLM502. It allows non-contact speed and length measurements

within limited space. The VLM500E is introduced on page 4.

In addition, you will find further news about our distance sensors and ASTECH in this second issue of *Sensitive*.

We hope you enjoy the second edition of our *Sensitive* in 2016,

Your ASTECH Team



VLM502 – especially suitable for compact industrial facilities

*In this edition*

Non-contact measurement of speed and length within limited space

VLM500E – Measurements at an increased distance

New products for distance detection

Successful Participation in the Business Run

□ Newly developed

## Non-contact measurement of speed and length within limited space

Whether in the planning and construction of new production facilities, or in the conversion of already existing ones with a given topology; the newly developed non-contact speed and length measuring device VLM502 is the perfect solution.



VLM502

Nowadays, the planning of new machines and systems is computer-aided. The entire structure is visualized with the help of 3D construction programs. By doing so, the space requirements are optimized and the accessibility or maintainability of individual assemblies (sensors or actuators) is evaluated before the plant is constructed.

A further situation arises during the conversion of existing production facilities (retrofit). Here, it is often the case that space for additional components is hardly given. Either the measuring device itself or its working distance is too large. In both cases, an installation of modern non-contact sensors is more difficult, if not impossible. The ASTECH GmbH has developed the new non-contact measurement device VLM502 in order to meet applications with limited space requirements.

### Compact remote measuring head

The idea was to design a measuring device, consisting of two subassemblies in order to divide the components. The development was based on a VLM500.

Due to a specific lens arrangement, the measuring object is imaged onto a photo-sensitive optical grating (CCD line). The signals of the CCD line are amplified analogously, structured and filtered.

This is followed by an analog to digital conversion for further data processing and data output, via various interfaces. Here, a separation point was created within this signal chain.

The part (first subassembly) of the VLM502 referred to as „measuring head“ accommodates an initial amplification of the sensor signal in addition to the LED lighting unit and the objective with CCD line.

All other components are accommodated in the second module, the „evaluation unit“ (see block diagram).

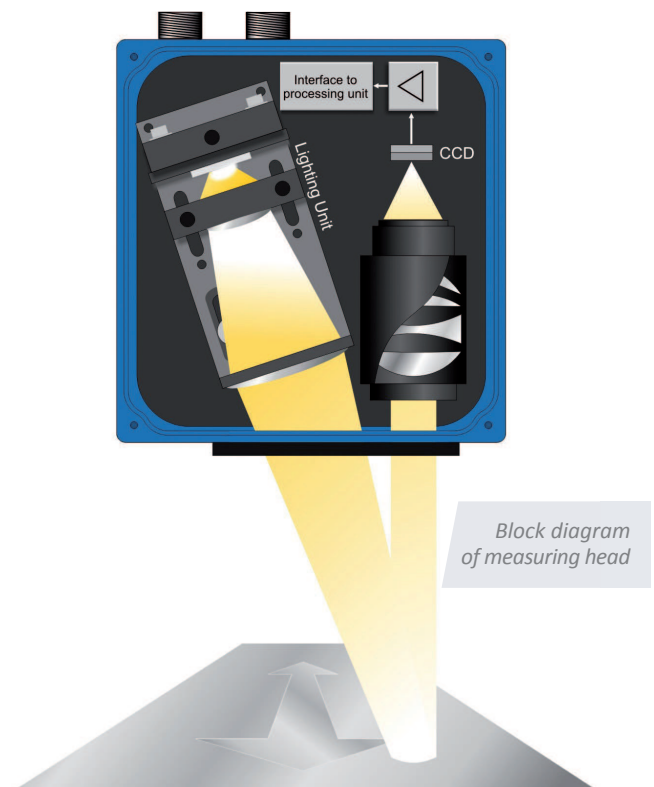

Block diagram of measuring head

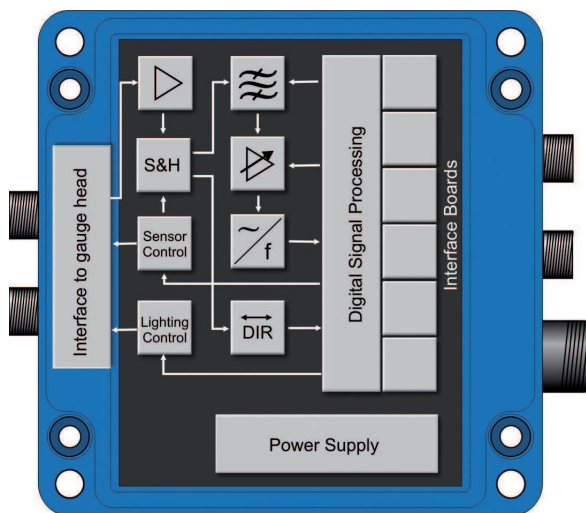

Block diagram of evaluation unit

In this way, the housing size of the measuring head has been halved compared to the VLM500.

In order to meet the demand for a shorter working distance, the receiving optic was also adapted. This made an additional reducing of the space requirement of the housing possible. This leads to the design of a specific aluminum housing, adapting itself to the space requirements of the internal components and surrounds them closely. The result is a considerably smaller measuring head housing compared to the VLM500, with a base

area of only 135 mm x 145 mm and a height of just 67 mm. Long-standing and proven construction principles, such as the special mounting of the internal base plate, have been retained in the design of the VLM502. Such as the VLM500, the housing of the VLM502 is also a very robust variant of the IP65.

### Evaluation unit with freely configurable interfaces

The second assembly accommodates the remaining components of the signal chain. The requirements for the housing size are lower for the evaluation unit. Therefore, an industrial standard housing made of aluminum die casting was used.

The evaluation unit is connected to the measuring head via cables. The use of plug connectors allows a simple installation of both modules. For the analysis unit, the mounting option has been adopted by the VLM500. So it is also possible to attach the device in the desired place, without removing the cover.

The VLM502 is already used in the automotive sector. The customer aims to record belt speeds contactless optical in engine test benches. Here, the available space is very limited. The VLM502 is therefore a perfect solution.

Further information on the technical characteristics of the VLM502 can be found on the website [www.astech.de](http://www.astech.de). ■

## VLM500E – Measurements at an increased distance

The non-contact measurement of speed and length device VLM has been an integral part of the ASTECH product portfolio for the last decades. The success of the sensor is mainly due to its steady development and expansion.

The new VLM500E allows measurements at an increased distance of 330 mm with a working range of 60 mm. Thus, the proven and reliable

product can be used even more efficient in demanding applications in the steel and aluminum industries, as well as in hot areas. All other features of the VLM series can be found in the VLM500E as well.

With this new development, ASTECH meets the special needs and demands of the market. In this regard, the close and deep customer relationship played an important role. As a result of this, ASTECH was able to

identify the desire for an extended working distance premature. Whereby, a fast realization was achieved and ASTECH is now even more able to provide high quality products and customer support.

Furthermore ASTECH announces that two members of the VLM500 series (VLM500A and VLM500L) have been optimized regarding their working range which is now 20 mm.



## New products for distance detection

ASTECH expands the product range for distance measurement devices with the products of the Canadian company LeddarTech™. The new product series offers a broad range of sensors using the patented Leddar™ technology. Special data processing methods designed by Leddar™ allow the usage of diffused LED impulses instead of Lasers for the time-of-flight measurement. Thereby the new sensors provide probably the best price-performance ratio. A big advantage of the new technology are structured receiver elements, which provide up to 16 simultaneous distance measurements with one common light source. This way of 2D distance detection works without any moving parts, which makes the sensor devices very robust and reliable. There are individually adjustable threshold values or each of the 16 distance measurements, which enable

the Leddar™ sensors to detect complex forms or measure length, width or height with just one sensor. Within the Leddar™ product series there are different OEM modules or ready-to-use distance meters available. With the Leddar™One ASTECH offers now a quite cost-effective OEM distance sensor module, which provides the possibility to integrate distance information into cost-sensitive electronic devices and equipment. The Leddar™One is able to measure the distance or to detect objects in a distance of up to 40 m with an accuracy of  $\pm 5$  mm. The flagship model of the series is the completely integrated sensor system IS16, whose industrial interfaces and robust housing make it well-equipped for harsh industrial applications. The IS16 provides 2D-distance detections with 16 segments. *More information shortly available under [www.atech.de](http://www.atech.de)*

□ Internal

## Successful participation in the business run

For the third time, the ASTECH team took successfully part in the Rostock business run. In the run's seventh edition, each member of the ASTECH team mastered the 3.5 km long running track at the port of Rostock. In bright sunshine, more than three hundred teams made their circuit.

The team event was once again a great opportunity for joint sports activities and casual networking.

We are looking forward to the next business run.



## Contact

**ASTECH Angewandte Sensortechnik GmbH**  
Schonenfahrerstr. 5, 18057 Rostock, GERMANY  
Phone: +49 381 44073-0  
Fax: +49 381 44073-20  
[sensitive@atech.de](mailto:sensitive@atech.de)

[www.atech.de](http://www.atech.de)

Simply scan the QR Code to open our website and gain information about ASTECH and our products.

