User Manual

LDS70A

Version 1.3



CE

Dear User,

You are advised to carefully read this User Manual before turning on the Laser Distance Sensor LDS70A for the first time.

This is necessary to ensure that you will be able to use all the capabilities and features provided by your new purchase.

This product is subject to ongoing technological developments.

| | |
|---------------------|----------------------------|
| Editorial deadline: | November 2023 |
| Firmware version: | ≥ 3.78 |
| Manual version: | V 1.3 |
| File: | Manual_LDS70A_EN_V1.3.docx |

Note:

Proper care has been used in compiling this document. No liability will be accepted in the event of damage resulting from the failure to comply with the information contained herein.

ASTECH GmbH, Schonenfahrerstr. 5, D-18057 Rostock
Internet: www.atech.de E-Mail: info@atech.de
Telephone: +49 (0)381 / 44073-0 Telefax: +49 (0)381 / 44073-20

Revision History

| Manual Version | Date | Changes |
|-----------------------|-------------|--------------------------------------|
| 1.3 | 20.11.2023 | Several updates and errors fixed |
| 1.2 | 16.11.2021 | Heating added |
| 1.1 | 02.04.2020 | Revision of Figure 5 and some errors |
| 1.0 | 04.02.2020 | Created |

I. Content

| | | |
|----------|--|-----------|
| 1 | General Information | 9 |
| 2 | Safety advice | 10 |
| 2.1 | Basic safety advice | 10 |
| 2.2 | Advice for operating device | 11 |
| 2.3 | Norms | 13 |
| 2.4 | Disposal | 13 |
| 3 | Operating conditions | 14 |
| 3.1 | Electrical installation conditions | 14 |
| 3.2 | Operating and storage conditions | 14 |
| 3.3 | Appropriate use | 15 |
| 3.4 | Improperly use – error sources | 15 |
| 4 | Device description | 17 |
| 4.1 | General information | 17 |
| 4.2 | Technical data | 17 |
| 4.3 | Laser beam image | 19 |
| 4.4 | Mechanical Installation | 20 |
| 4.5 | Electrical Installation | 21 |
| 4.6 | Status LED | 22 |
| 4.7 | Automatic heating | 22 |
| 4.8 | Serial interface RS232 | 23 |
| 4.9 | Serial interface RS422 | 24 |
| 4.11 | Digital interfaces Q1, Q2 | 25 |
| 4.12 | Analogue current output QA | 26 |
| 4.13 | Trigger | 28 |
| 5 | Parameter setup and measurement | 30 |
| 5.1 | General information | 30 |
| 5.2 | Transmission protocol | 30 |
| 5.3 | Identification | 31 |
| 5.4 | Operation modes | 33 |
| 5.5 | Status | 34 |
| 5.6 | Parameter | 37 |
| 6 | Error processing | 59 |
| 7 | Accessories | 61 |
| 8 | EG Declaration of conformity | 62 |

II. List of Figures

| | |
|--|----|
| Figure 1 : LDS70A dimensions | 20 |
| Figure 2: M12, 12-pin cable socket - pin page (front view) | 22 |
| Figure 3: Wiring with serial interface RS232 | 23 |
| Figure 4: Wiring with serial interface RS422 | 24 |
| Figure 5: Wiring of Q1, Q2..... | 25 |
| Figure 6: Wiring of QA..... | 27 |
| Figure 7: Wiring of trigger output..... | 28 |
| Figure 8: Wiring of trigger input..... | 29 |
| Figure 9: Analog output behaviour..... | 44 |
| Figure 10: Switching behavior of Q1 and Q2..... | 47 |

III. List of tables

| | |
|---|----|
| Table 1 : Electrical installation conditions..... | 14 |
| Table 2: Technical data | 17 |
| Table 2: Laser spot size | 19 |
| Table 3: Connector pin assignment | 21 |
| Table 4: Power consumption of internal heating | 22 |
| Table 5: Explanation of hardware status items | 35 |
| Table 6: Description of gain steps | 39 |
| Table 7: Comparison of Gain steps and Gain values..... | 39 |
| Table 8: Binary output - Maximum measurement frequency (MF_{max}) . | 41 |
| Table 9: Decimal output - Maximum measurement frequency (MF_{max}) | 42 |
| Table 10: Measurement window - output behavior | 43 |
| Table 11: Mean value outcome | 48 |
| Table 12: Parameter SD - Output encoding | 49 |
| Table 13: Output behavior on error | 51 |
| Table 14: Available termination chars | 54 |
| Table 15: Error codes | 59 |
| Table 16: Common accessories | 61 |

Es konnten keine Einträge für ein Abbildungsverzeichnis gefunden werden.

Used Symbols



Sign warns against emitting visible and invisible laser radiation.



Sign warns against danger of electrical power and of electric shock.



Sign warns against danger.



Sign shows information for use in hazardous environments.



Sign indicates important information regarding use of the device.



The sign shows protection class 3 (protective extra-low voltage).



Sign indicates degree of protection (IP) of the device.



Sign informs that special guidelines had to be applied for device disposal.

1 General Information

The laser distance sensor LDS70A was developed for industrial applications. It enables non-contact measurement of distances in a large working range and with a high sampling rate up to 40 kHz to almost any diffusely reflecting surface to 70 m and up to 320 m on reflectors. The sensor uses an eye-safe laser radiation at a wavelength of 905 nm (infrared).

The IP67 housing of the LDS70A is impact and shock resistant and ideally suited for use in harsh industrial environments.

The LDS70A has a selectable RS232 and RS422 interface, an analog output and 2 digital outputs.

The LDS70A is characterized by very compact and rugged design, easy mounting, low power, adjustable switching outputs and the ability to set user-specific parameters. This opens up a variety of uses in industrial applications.

- Rapid process monitoring
- Position monitoring
- Level measurement
- Monitoring of object movements
- Positioning of cranes and loading equipment
- Measurement of inaccessible points, for example in cavities, pipes and containers
- Particularly suitable for use in scanners

The LDS70 sensor operates on the basis of time of flight measurement. Short laser pulses are transmitted. The light pulse reflected from the target is detected by the receiver. The distance can be determined by the time shift. The measurement range depends on the reflectivity and the surface type of the measured target.

2 Safety advice

2.1 Basic safety advice

Please read the safety and operating advice carefully, and observe the advice when operating the device.



Danger of Laser radiation

Do not open the LDS70A, otherwise Laser radiation can be emitted that can cause eye injuries. Please observe all information and guidelines for operating the Laser.

The LDS70A corresponds to Laser class 1 based on the standard IEC 60825-1:2014. The radiation of class 1 Lasers does not imply any danger to the human eye; any injury of the human eye can be excluded.



Danger, electric shock

The LDS70A may only be opened for repair purposes by the manufacturer. If the device is opened arbitrarily without authorization, all warranty claims will expire.



The **operating and storage conditions** have to be observed (see chapter 3). The inobservance of this advice and the adverse use of the device can lead to injuries of the user or to damage of the device.



Connectors may not be plugged or unplugged when voltage is applied. All installation work may only be carried out when no voltage is applied.



The device may only be **operated as intended** and in faultless condition.

Safety installations must not be rendered ineffective.

Safety and warning signs must not be removed.



Protection Class 3, low voltage

The device LDS70A operates with low voltage of DC 10 to 30 volts.



Protection degree: In accordance with the **Protection Degree IP 67**, the LDS70A is protected against jet water and dust, and against short submersion into water.

When operating the device under extreme outdoor environmental conditions, the use of additional weather protection is recommended (e.g. a cover plate with a short distance to the LDS70A). Rapid temperature changes can lead to humidity entering the device.



The device is **not shatter-proof**. Do not let the device fall onto the ground, and avoid any shock.

The device is delivered in a solid cardboard box, which is suited for the transport of the device.



The device may **not be used in explosive environments**; otherwise there is the danger of damage to the LDS70A and the surrounding equipment, and of injuries of the user.

2.2 Advice for operating device



The LDS70A should not be put into operation when optical parts are fogged or dirty. The optical components of the equipment should not be touched with bare hands!

Dust and dirt are removed from the optical components with extreme caution! Cleaning with solvents or mechanical means is not allowed.



The device must be protected against overheating. The device will not be switched off automatically when the operating temperatures are exceeded. The persisting overheating of the device will lead to a reduced lifetime of the laser diode.



The device must be protected from impact.

The device must be protected from extreme temperature fluctuations. When extreme temperature fluctuations are occurring use additional protection housing.



It is not allowed to operate the device in explosive environments.



The device corresponds to the protection degree IP 67, and is protected against jet water and short submersion. Please observe the conditions for the protection degree IP 67, and observe especially the following advice:

- The device must not be exposed to persisting driving rain or high temperature variations.
- If the device is exposed to humidity, the temperature difference between the device and the environment may be $\pm 5\text{K}$ maximum.



It is necessary to observe the operating and storage conditions.

2.3 Norms

The device conforms to the following norms:

- | | |
|---------------------------------------|--|
| EN 61326-1:2013 (IEC 61326-1:2012) | Electrical equipment for measurement, control and laboratory use, EMC requirements Part1: General requirement |
| EN 50581:2012 | Technical documentation for the assessment of electrical and electronic products with respect to the restriction of hazardous substances |

The following additional standards/specifications were considered:

- | | |
|---------------------------------------|---|
| EN 60825-1:2014 (IEC 60825-1:2014) | Safety of Laser products - Part 1: Equipment classification, requirements and user guide Laser Class 1 |
|---------------------------------------|---|

2.4 Disposal



For the disposal of the device, special environmental protection guidelines apply. Do not dispose the device with the usual domestic refuse. The manufacturer offers to take back the device after the end of the product life cycle, and to dispose of the product in accordance with the effective environmental protection guidelines. Please note that this service is subject to a charge.

3 Operating conditions

3.1 Electrical installation conditions

For the operation of LDS70A use only a DC voltage of 10 V ... 30 V.



The limit values for the input voltage have to be observed. Do not wire inputs as outputs.

All outputs are short circuit proof. The housing is galvanically separated from the sensor electronics assembly. The interference resistance at electrostatic discharge (ESD) is 4 kV according to EN 61326-1.

Table 1 : Electrical installation conditions

Electrical installation conditions of LDS70A

| | |
|-------------------|---|
| Supply voltage | 10 V ... 30 V DC (direct current voltage) |
| Power consumption | < 3 W |

3.2 Operating and storage conditions

Operating temperature -40 °C ... +60 °C

Storage temperature -40 °C ... +70 °C

Air humidity 15 % ... 90 % non-condensing



The mentioned **operating and storage conditions** have to be observed. When the operating temperatures exceed the permitted values, the device will not be switched off automatically. The continuous overheating of the device will reduce the lifetime of the laser diode.



The inner temperature of the LDS70A can be distinctly higher than the ambient temperature. If the inner temperature exceeds 85 °C no laser light will be emitted until the temperature falls below 85°C again.



The temperature (check with command TP) may be higher than the ambient temperature. Approx. 30 min after power ON the measured temperature might be 25 Kelvin higher than ambient temperature.

3.3 Appropriate use

The device is intended for the following applications:

Distance measurement and output of measured data via RS-232 or RS-422 interface, analogue output and digital outputs.

It should be noted:

- Operation with correct supply voltage,
- Compliance with environmental conditions, the operating and storage temperature,
- Protection of windows against fogging and soiling,
- Using data lines with specified signal levels,
- Observing of guidelines in this manual.



Measurement through optically transparent material

Measurement through optically transparent materials such as glass, optical filters, acrylic glass etc. can lead to erroneous measurement results. When measuring through optically transparent material, use the function “measurement window”. By using this function due to setting a fixed measurement range, a wrong measurement - caused by an optical medium in front of the laser - may be avoided. Please take care that the surface of the medium is clean and clear.

3.4 Improperly use – error sources

The device may only be used when the safety advice described in chapter 2 is observed. The non-observance of the safety advice can lead to damages of the device or to injuries of the eyes.

To achieve correct measurement results, avoid the following error sources:

- Measurement against the sun or other intense light sources
- Measurement onto low reflective target surfaces in highly reflective environments
- Measurements onto highly reflective surfaces (mirror)

- Measurements through glass, optical filter, Plexiglas or other transparent materials can lead to measurement errors
- Two or more LDS70A may not be aligned in "frontal view" because the devices interact each other
- Operation and storage of the device under conditions that do not conform with the specifications

4 Device description

4.1 General information

The laser distance meter LDS70A is designed as a compact range finder dedicated for easy integration. It provides serial data interfaces (RS232, RS422) as well as digital and analog outputs. The housing is classified IP 67. The automatically controlled heating element ensures the operating temperature of the components and free optics (no condensation) of the LDS70A.

4.2 Technical data

Table 2: Technical data

| Measurement | |
|---|---|
| Measurement principle | Laser pulse - Time of flight measurement |
| Measuring range | |
| Total range | 0.2 m ... 270 m |
| On target board ¹⁾²⁾ | 0.5 m ... 270 m |
| Onto natural surface, 80 % reflectivity ¹⁾ | 0.2 m ... 125 m |
| Onto natural surface, 10 % reflectivity ¹⁾ | 0.2 m ... 70 m |
| Measuring accuracy ³⁾ | ±60 mm (single measurement, 1 σ) |
| Repeatability ⁴⁾ | ±25 mm (1 σ) |
| Resolution | 1 mm (decimal output \leq 15 kHz) |
| Maximum measuring rate | 40 kHz |
| Measurement modes | Single, continuous, programmable auto-start |

¹⁾ Dependent on target reflectance, influence of extraneous light and atmospheric conditions

²⁾ e.g. Scotchlite Cube 3000x

³⁾ Accuracy can be \pm 100 mm for close-up ranges up to 1 m.

⁴⁾ Repeatability \pm 50 mm at measurement distances above 70 m.

| Laser | |
|------------------|-----------------------------------|
| Laser wavelength | 905 nm (invisible, near-infrared) |
| Laser divergence | 2 mrad x 0.4 mrad |
| Laser class | Laser class 1, EN 60825-1:2014 |

Electrical

| | |
|------------------------------|---|
| Power supply | +10 V DC... 30 V DC |
| Power consumption (maximum) | ≤ 3 W (without heating) ≤ 8 W (with active heating and Vcc= 24V) |
| Connector flange (on device) | Standard M12, male connector, 12-pin, A-coded |

Interfaces

| | |
|-----------------------|---|
| Serial data interface | RS232 or RS422, Max. baud rate 921.600 baud/s |
| Digital output | 2x "High-Side" switch, max. load 0.2 A |
| Analog output | 4 mA ... 20 mA, programmable distance ranges |
| Trigger | 1x in/out, programmable delay |

Environmental

| | |
|-----------------------|---|
| Operating temperature | -20° C ... +60 °C (without heating) -40° C ... +60 °C (with enabled heating) |
| Storage temperature | -40 °C ... +70 °C |
| Humidity | 10 % ... 90 %, non-condensing |
| Integrated heating | Yes, automatically controlled |

Mechanical

| | |
|--------------------------|--|
| Housing protection class | IP 67 |
| Shock / Vibration | DIN ISO 9022-3 |
| Dimensions | 98 mm x 46 mm x 25 mm (L x W x H) incl. connector |
| Weight approx. | 137 g |
| MTTF | > 5 years (> 44.000 hours) |





4.3 Laser beam image

Divergence of Transmitter: 2 mrad x 0.4 mrad

Divergence of Receiver: 5.8 mrad

The table below shows the size of the laser spot on the target in dependence on the distance. In this sight the lenses of the RF70A are installed vertical above each other.

Table 3: Laser spot size

| Distance | Laser Width | spot | Laser height | Spot | Footprint (not true scale) |
|----------|-------------|------|--------------|------|---|
| 0.2 m | 14 mm | | 9 mm | |  |
| 1 m | 14 mm | | 10 mm | | |
| 5 m | 15 mm | | 19 mm | |  |
| 10 m | 17 mm | | 30 mm | | |
| 20 m | 19 mm | | 51 mm | | |
| 70 m | 32 mm | | 157 mm | |  |
| 150 m | 52 mm | | 327 mm | | |
| 290 m | 87 mm | | 625 mm | |  |

The above-mentioned laser spot holds approx. 50 % of the entire laser energy. An aura with less energy forms around that spot.

4.4 Mechanical Installation

The LDS70A can be mounted in 3 different ways:

- Front with 2 screws M3
- Bottom side with 4 screws M3
- Small side right with 3 screws M3

The required length of the screws depends on the counter piece. It is recommended to use screws with washer and ring washer. Exact positions of the screws are shown in Figure 1.



Mounting screws are not included in scope of delivery.

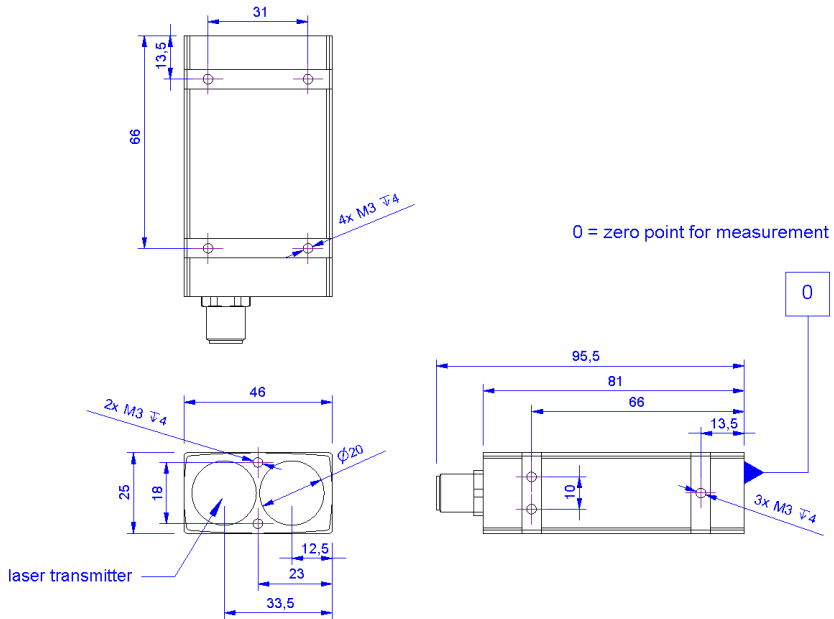

Figure 1 : LDS70A dimensions

4.5 Electrical Installation

Connector pin assignment

Table 4: Connector pin assignment

| Pin | Color | Signal | Description |
|-----|-------------|---------------|--|
| 1 | Brown | Q1 | Digital output Q1 |
| 2 | Blue | VDC - | GND of supply voltage |
| 3 | White | RS422 / RS232 | Setting pin RS422 or RS232 |
| 4 | Green | TX+ TxD | RS422 transmission data + RS232 transmission data |
| 5 | Pink | RX- | RS422 receiving data - |
| 6 | Yellow | TX- | RS422 transmission data - |
| 7 | Black | Q2 | Digital output Q2 |
| 8 | Grey | RX+ RxD | RS422 receiving data + RS232 receiving data |
| 9 | Red | VDC + | Supply voltage 10 V ... 30 V DC |
| 10 | Violet | TRIGIO | Trigger signal IN / OUT |
| 11 | Grey / Pink | QA | Analogue current output 4 mA ... 20 mA |
| 12 | Red / Blue | GND | Ground for interfaces (QA, RS232, Trigger) |

- The LDS70A provides inverse polarity protection
- Overvoltage protection is provided up to max. 42 V DC
- Recommended cable socket: Standard M12, female, 12-pin



The shield of the cable should be connected to the connector housing. Open, unused cable wires must be insulated.

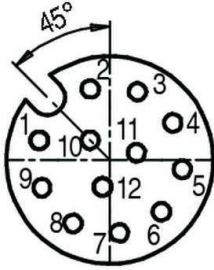

Figure 2: M12, 12-pin cable socket - pin page (front view)

4.6 Status LED

The LDS70A has a measurement control LED on the back panel near to the connector flange. Following conditions will be indicated automatically:

- The LED is flashing green during measuring without a failure.
- The LED is flashing red if the device detected a critical failure during measurement which cannot be cleared automatically.
- The LED lights permanently green if continuous measurement is inactive.

4.7 Automatic heating

The LDS70A is equipped with an integrated automatic heating. It will be activated if the internal temperature drops below +4 °C and works until an internal temperature of +8 °C is reached.

With activated heating the power consumption of the LDS70A increases. The heating is directly fed by the power supply.

Table 5: Power consumption of internal heating

| Power supply voltage | Power consumption of heating |
|----------------------|------------------------------|
| 10 V | 1 W |
| 24 V | 5 W |
| 30 V | 7.5 W |

4.8 Serial interface RS232

The RS232 serial interface can be used for data transfer and configuration of the LDS70A. The cable length is limited to 15 m. The cable length has to be shorter at baud rates above 115200. For these baud rates, we recommend to use the RS422 interface of the LDS70A.

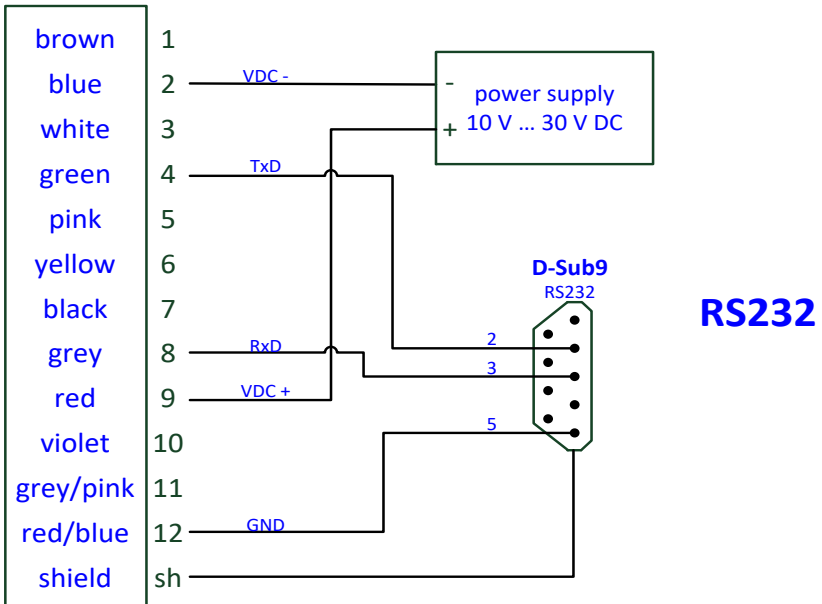

Figure 3: Wiring with serial interface RS232

Before using the serial interface in RS232 or RS422 the correct wiring of Pin 3 (white) has to be checked.



- | | |
|-------|-----------------------------------|
| RS232 | PIN 3 not connected (open) |
| RS422 | PIN 3 connected with PIN 12 (GND) |

4.9 Serial interface RS422

The RS422 serial interface can be used for data transfer and configuration of the LDS70A like the RS232. Cable length depends on the baud rate and the line quality; up to 300 m length is possible. Use only high-quality cable with 2 twisted pairs and shielding.

Pin 3 (white) of the connector decides which kind of serial interface active. For RS422 the pin has to be connected to GND (pin 12, red/blue).

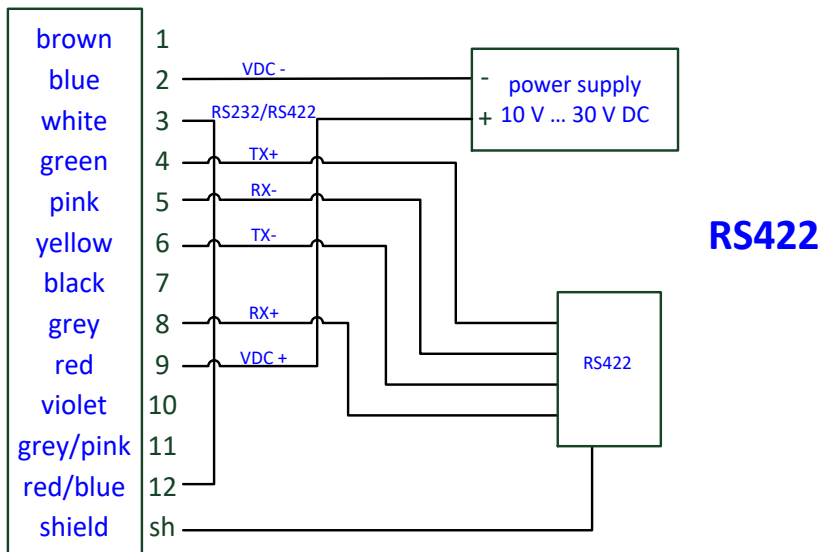

Figure 4: Wiring with serial interface RS422

4.11 Digital interfaces Q1, Q2

Switching outputs Q1 and Q2 show the distance information as logical switching information. They signalize whether the preset hysteresis switching range is exceeded or fallen short of.

Thus, they are ideally suitable for direct further processing of monitored values such as fill level or object detection. Parameterization is done via the serial interface.

A load resistor of $> 150 \text{ Ohms} / 6 \text{ W}$ (max. operating voltage of 30 V ; max. load current of 0.2 A) has to be switched against VDC- (GND of supply voltage).

The load current must not exceed 0.2 A.



Typical resistance: 1 kOhm against VDC- (not against GND)!

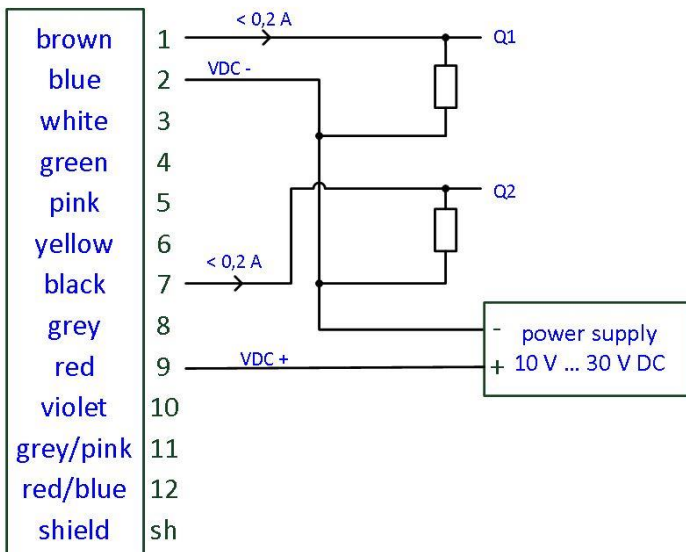

Figure 5: Wiring of Q1, Q2

The correct behavior of the digital switching outputs is controlled by the parameters Q1 and Q2. See chapter 5.6 for further information.

4.12 Analogue current output QA

The analogue output enables standardized analogue distance data transfer over long distances by means of a two-wire line. The current of 4...20 mA impressed in the line is proportional to the measured distance within an adjustable distance interval.

Analogue output properties:

- 4 mA ... 20 mA
- Indication in case of error: 3 mA or 21 mA or last measured value
- 16 bit digital-to-analogue converter
- Max. resolution for 4...20 mA range: 15 bit

If current/voltage is to be converted, there must be a load resistor of < 500 Ohms/0.5 W (12 V of internal voltage --> max. measuring current of 24 mA) between current output QA and GND.



Please do not use the analog output for fast processes with high distance changes. The typical settling time for a jump between 4 mA and 20 mA will be 40 μ s.

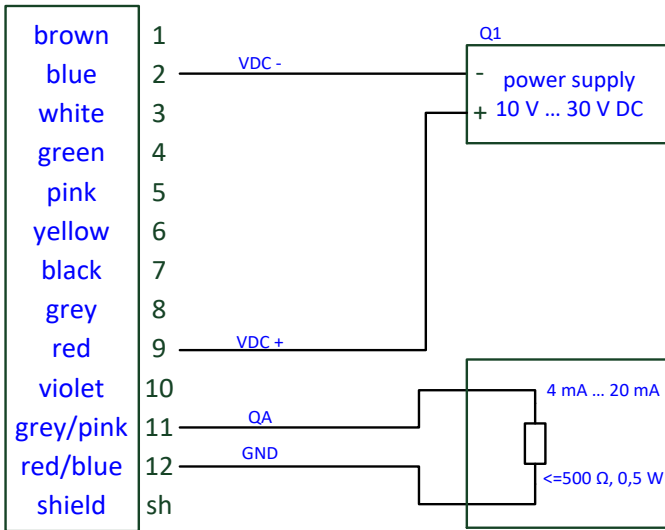

Figure 6: Wiring of Q1

4.13 Trigger

The LDS70A Trigger may be used as input or output.

1. Trigger input – externally initiated measurement
 External trigger signal will be sent to LDS70A to start a single measurement like DM in accordance with parameter TI.
2. Trigger output - connection between two devices:
 The output trigger signal of the 1. LDS70A (parameterized with TO) starts a single measurement DM of the second LDS70A (parameterized with TO).
3. Continuous distance tracking controlled by trigger

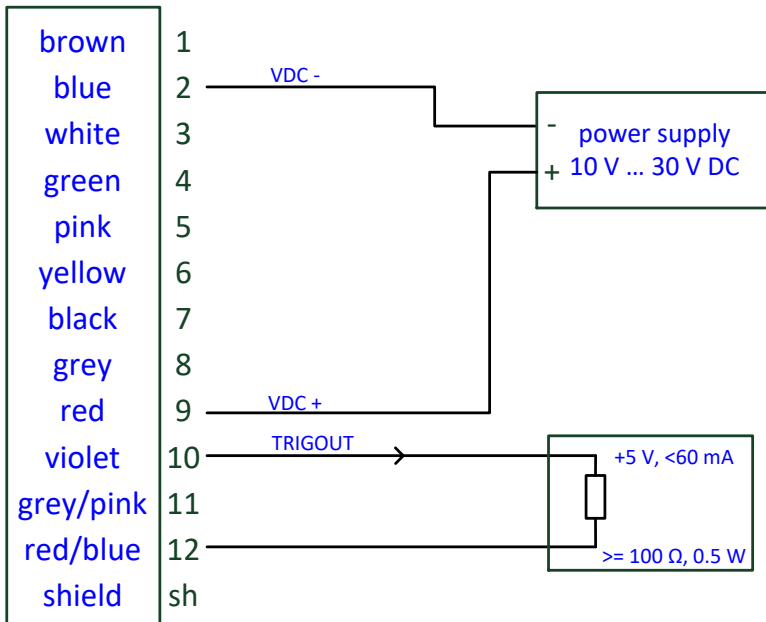

Figure 7: Wiring of trigger output

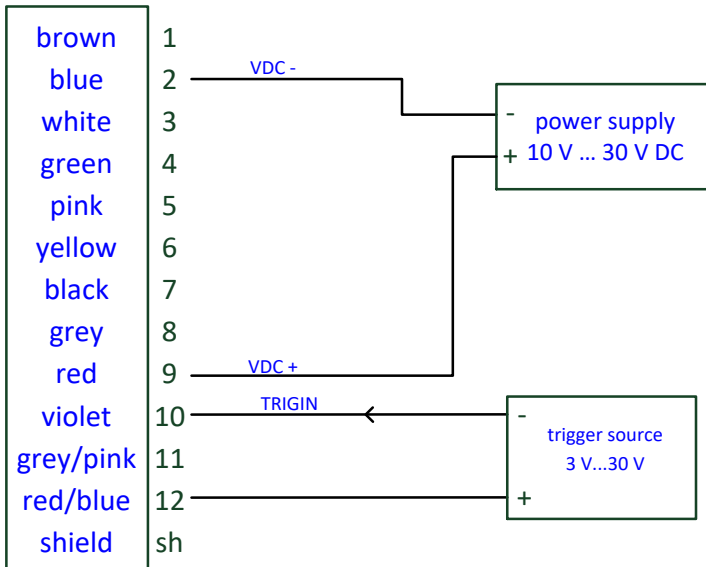

Figure 8: Wiring of trigger input

Voltage levels for the trigger signals:

| | |
|------------|---------------|
| Low level | 0 V ... 1.5 V |
| High level | 3 V ... 30 V |
| Threshold | 2.25 V |
| Hysteresis | 0.1 V |

For correct parameterization of trigger input or output mode please refer to chapter 5.6

5 Parameter setup and measurement

5.1 General information

The LDS70A is parameterized using the serial interface. Precondition for programming via UART is a connection provided by a terminal program (e.g. HyperTerminal, Tera Term). The set parameter values are stored in the EEPROM immediately. The last entered data will be available upon restarting.

5.2 Transmission protocol

Both serial interfaces use the same transmission protocol:

- Interface settings: Asynchronous, 8 data bits, no parity, 1 stop bit
- Transmission protocol format / syntax: 7 bit ASCII
- Proprietary transmission protocol
- Commands are case-insensitive (no differentiation between lower and upper case).
- Decimal separator in the output of figures is the dot “.” (0x2E).
- The terminator of a command (sending command) is ENTER (0x0D, 0x0A) or Carriage Return (0x0D)
- Where parameters have several values, they are separated by a space (0x20).
- The response to commands with parameters is the respective command including the parameters.
- The response to commands without parameters is the respective command including the current parameters.
- The response to commands with parameters outside of the valid value range is the respective command including the current parameters.
- The response to unknown commands and faulty parameter formats is a “?” (0x3F).
- The response time on a received command varies. Read commands will be answered quite fast while commands to set parameters may take up to 300 ms to be confirmed.

- Distances are always entered in meter (m) with 3 decimal places after the separator.
631 cm Input: 6.310
5.123 m Input: 5.123
- Retrieve parameter values
Input: PARAMETER<CR (0x0D)>
- Set parameter values
Input: PARAMETER VALUE1 VALUE2<CR (0x0D)>
- Starting a measurement (operating mode)
Input: COMMAND<CR (0x0D)>
- Stopping a measurement (continuous operating mode)
Input: <ESC (0x1B)>

The set parameters are stored in the non-volatile EEPROM immediately. The last entered data will be available upon restarting.

5.3 Identification

ID - Device identification information

When entering the command ID, the LDS70A will respond by displaying the device identification information in the order ID, serial number, firmware version.

Query: ID<CR (0x0D)>

Response: ID SN 180004 V3.38R 630 (example)

ID? – Online help

By entering the command ID? the user will obtain an overview of all available commands and parameters.

Query: ID?<CR (0x0D)>

Response: Operation Mode
 DM[Enter].....single distance
 DT[Enter].....continuous distance
 Status
 TP[Enter].....internal temperature [°C]
 HW[Enter].....hardware status
 PA[Enter].....display parameter
 Setup Parameter
 PR[Enter].....reset parameter
 DR[Enter].....reset device
 AS[Enter]/ASs[Enter].....display/set autostart
 command
 MF[Enter]/MFx[Enter].....display/set measure
 frequency
 GN[Enter]/GNx[Enter].....display/set receiver gain
 SA[Enter]/SAx[Enter].....display/set average value
 MW[Enter]/MWx y z[Enter]....display/set measure window
 OF[Enter]/OFx[Enter].....display/set distance offset
 SO[Enter].....set current distance to
 offset
 SE[Enter]/SEx[Enter].....display/set error mode
 Q1[Enter]/Q1w x y z[Enter]..display/set digital out Q1
 Q2[Enter]/Q2w x y z[Enter]..display/set digital out Q2
 QA[Enter]/QAx y[Enter].....display/set analog out QA
 BR[Enter]/BRx[Enter].....display/set serial baud rate
 SD[Enter]/SDx y[Enter].....display/set serial output
 format
 UB[Enter]/UBx[Enter].....display/set unit for binary
 output
 TE[Enter]/TEx[Enter].....display/set serial
 terminator
 ST[Enter]/STx[Enter].....display/set first or last
 target for outout
 TC[Enter]/TCx[Enter].....display/set DT recalibration
 timing x in sec (0 off)
 TI[Enter]/TIx y[Enter].....display/setup input trigger
 TO[Enter]/TOx[Enter].....display/setup output trigger

5.4 Operation modes

DM – Single distance measurement

LDS70A performs one distance measurement, transmits the result and then it waits for new commands. The duration of the measurement depends on the setting of parameters SA (averaging) and MF (measurement frequency).

Input: DM

DT – Continuous distance measurement (distance tracking)

In DT mode the LDS70A performs continuous measurements. The operation can be stopped by sending ESC (Escape, 0x1B).

The resulting output frequency is determined by the current setting of parameters SA (averaging), MF (measurement frequency) and SD (output format).

Input: DT

Response: Example for SD 0 3

D 0002.935 21.1 57,2

Output format = decimal (D)

Distance = 2.935 m

Signal quality = 21.1

Temperature = 57.2 °C



The output frequency of DT depends on the baud rate settings (BR). If the baud rate is too low not all measured values can be transmitted over the serial interface.



The internal temperature of the device is not the same as the operating temperature stated in the technical data (see chapter 4.2)! The internal Temperature will be approximately 25 Kelvin higher as the ambient temperature.

5.5 Status

TP – Internal temperature

Retrieving the current internal temperature of the LDS70A in °C

Query: TP
Response: TP 048.4



The user of the LDS70A has to ensure that the stated ambient temperature (operating temperature) is adhered to. If the allowed ambient temperature range is exceeded the will be no measurements and an error message will be generated.

HW –Hardware status

A device-specific list of parameters and measurements is shown. All parameters are internal information regarding the hardware status, changes are not possible.

Input: HW
Response: Temp (Board) 45.0°C
Laser voltage 25485mV
Measure Result 0

Table 6: Explanation of hardware status items

| Hardware status item | Description |
|----------------------|---|
| Error code | Fault indication |
| Temp (Board) | Temperature of the controller (internal) |
| Laser-Voltage | Supply voltage of laser diode driver circuit |
| Measure result | Classification of measurement conditions 0 – Measurement o.k. 1 – Out of measurement window (MW) 2 – Invalid pulse width 3 – Small pulse width 4 – Sistance out of range 5 – Noise pulses detected 6 – No pulses |

PA – Parameter overview

In response to the query PA the LDS70A will send a parameter list with current settings.

Query: PA

Response Example

```
measure frequency[MF].....500 (max 40000)Hz
average value[SA].....2
measure window[MW].....-290.000 290.000 0
trigger in[TI].....internal trigger
trigger out[TO].....rising edge
distance offset[OF].....0.000
error mode[SE].....1
digital out[Q1].....0.000 1.000 0.050
1
digital out[Q2].....0.000 1.000 0.050
1
analog out[QA].....0.000 1.000
receiver gain[GN].....0
serial baud rate[BR].....115200
serial output format[SD].....dec (0),
value+amplitude (1)
unit for binary output[UB].....1000.000
serial output terminator[TE].....0Dh0Ah (0)
autostart command[AS].....DT
```

```

select target[ST].....0/first
recalibration timing[TC].....1 sec/enabled

```

PR – Parameter reset

All parameters are reset to the factory settings except baud rate (BR) and target selection (ST).

Query: PR

Response:

```

reset parameter
measure frequency[MF].....10000(max 40000)Hz
average value[SA].....1000
measure window[MW].....-290.000 290.000 0
trigger in[TI].....internal trigger
trigger out[TO].....rising edge
distance offset[OF].....0.000
error mode[SE].....1
digital out[Q1].....0.000 1.000 0.050
digital out[Q2].....0.000 1.000 0.050 1
analog out[QA].....0.000 1.000
receiver gain[GN].....0
serial baud rate[BR].....115200
serial output format[SD].....dec (0), value (0)
unit for binary output[UB].....1000.000
serial output terminator[TE]...0Dh0Ah (0)
autostart command[AS].....DT
select target[ST].....0/first
recalibration timing[TC].....1 sec/enabled

```

DR – Device reset (sensor restart)

DR executes a cold start of the RF70A and practically simulates a voltage interruption. This command is useful when the autostart command has been changed.

Query: DR

Response: Device reset

5.6 Parameter

AS – Auto start

The autostart function determines what the RF70A does after a cold start. Upon connection to the supply voltage and after the internal switch-on routine, the RF70A carries out the command automatically and sends the data to the available outputs.

| | |
|--------------|---|
| Query: | AS |
| Set | ASx |
| Value range: | BR, DM, DT, HW, ID, ID?, MF, MW, OF, PA, PR, Q1, Q2, QA, SA, SE, SD, TE, TP |
| Standard | DT |



The time duration between switching on the supply voltage and the output of the first measured value is max. 750 ms (if SA=1).

BR – Baud rate

BR enables the adjustment of the serial baud rate. As soon as a new baud rate has been set, the device will immediately start to communicate based on that new baud rate. Adjust the baud rate of the connected receiver according to the new value of BR.

| | |
|--------------|---|
| Query: | BR |
| Set | BRx |
| Value range: | 9600, 19200, 115200, 230400, 460800, 921600, 1843200, 2000000 |
| Standard | 115200 baud / 8 data bits / 1 stop bit / no parity |

Input: BR 115200
Output: BR 115200



Setting a very high baud rate implies a risk. Some computers are unable to support a baud rate of 460 800, for example. If the baud rate is set via the command BR460800, communication will no longer be possible without an interface converter, i.e. it will be impossible to reset the baud rate to a lower value without any auxiliary means!

GN – Gain setup

GN parameterizes the amplification of the receiver channel.

Query: GN
Set: GNx
Value range: -1, 0, 1, 2, 3 10 ... 10000 (see Table 7 and Table 8)
Standard: 0
Input: GN 2
Output: GN 2

Meaning of GN >10 sets the gain value for amplification directly

Table 7: Description of gain steps

| Value | Description |
|---------------|--|
| GN -1 | Automatic control of amplification depending on the received light |
| GN 0 | Fix gain step with optimal gain setting for most applications |
| GN 1 ... GN 3 | Fix gain steps with higher gain than GN 0 |
| GN 10...10000 | Individual adjustment of gain by direct entry of gain value |

Table 8: Comparison of Gain steps and Gain values

| Gain step | Gain value direct | Gain voltage |
|-----------|-------------------|--------------|
| 0 | 192 | 0.576 V |
| 1 | 267 | 0.801 V |
| 2 | 337 | 1.011 V |

Calculation: $\text{Gain voltage} = \text{Gain value} * 0,003 \text{ V}$

- The bigger the gain value is selected, the higher is the gain voltage and with that the amplification of the received signal.
- Higher amplification allows to detect bad reflecting surfaces in big distances, but reduces the accuracy.
- Low amplification reduces the number of interference pulses in near field measurements on good reflecting targets.
- Gain values above 1000 are only recommend for applications with big distance ranges and bad reflecting targets.

MF – Measurement frequency

MF parameterizes the number of single pulses to be transmitted per second. This is also the number of single distance measurements per second.

Query: MF
Set: MFx
Value range: 1 ... 40000, resolution 1
Standard: 10000
Example:
Input: MF 1000
Output: MF 1000 Hz

The achievable output frequency depends on the following terms of the setup:

- Used interfaces (e.g. serial interface RS232 or RS422, analog output)
- length of the interface cable
- transfer speed (baud rate)
- average (parameter SA)
- data format of output value (binary, decimal → parameter SD)
- number of output values (distance, signal strength, temperature → parameter SD)



The number of transmitted distance values is directly connected to the parameters MF and SA (average):

$$\text{Output rate} = \text{MF} \times \text{SA}$$

Example: With MF = 1 and SA = 1000 one measurement is done every second, but the output time is about 17 minutes (1000 s).



The baud rate setting (BR) is responsible for the limitation of the output rate. Please check the dependence of measuring frequency/ output frequency with baud rate and data format of serial interface output (SD) in the tables below. If measuring frequency will be higher as the values in the table, some of the measured distance values will be lost. Please double check with a new setting of measuring frequency MF the BR setting.

Table 9: Binary output - Maximum measurement frequency (MF_{max})

| Output values | Distance | Distance + signal quality | Distance + temperature | Distance + signal quality + temperature |
|--------------------------|---|------------------------------|---------------------------|---|
| Output data format | SD 2 0 | SD 2 1 | SD 2 2 | SD 2 3 |
| Length of output data | 2 | 3 | 3 | 4 |
| Baud rate | Maximum output frequency = MF_{max} with SA 1 | | | |
| 9600 | 470 | 300 | 300 | 220 |
| 19200 | 900 | 600 | 600 | 450 |
| 115200 | 5750 | 3800 | 3800 | 2880 |
| 230400 | 11600 | 7700 | 7700 | 5800 |
| 460800 | 23200 | 15500 | 15500 | 11600 |
| 921600 | 40000 | 30300 | 30300 | 23000 |
| 2000000 | 40000 | 40000 | 40000 | 34000 |

Table 10: Decimal output - Maximum measurement frequency (MF_{max})

| Output values | Distance | Distance + signal quality | Distance + temperature | Distance + signal quality + temperature |
|------------------------------|---|---------------------------|------------------------|---|
| Output data format | SD 0 0 | SD 0 1 | SD 0 2 | SD 0 3 |
| Length of output data | 11 | 16 | 17 | 22 |
| Baud rate | Maximum output frequency = MF_{max} with SA 1 | | | |
| 9600 | 80 | 50 | 48 | 40 |
| 19200 | 160 | 100 | 90 | 75 |
| 115200 | 1000 | 700 | 660 | 480 |
| 230400 | 2000 | 1400 | 1300 | 980 |
| 460800 | 4100 | 2750 | 2500 | 1850 |
| 921600 | 7300 | 4750 | 4350 | 3300 |
| 2000000 | 12200 | 7850 | 6480 | 5000 |

MW – Measurement window

The measurement window defines the general distance boundaries for a successful measurement, starting at distance x and ending at distance y. The third parameter z sets the output value for the case that a successful distance measurement results outside the measurement window boundaries.

The measurement window function is useful for:

- Blanking out interfering objects before or behind a certain distance range
- Determining a defined measurement range

Query: MW

Set: MWx y z

Value range x: Float32, resolution 0.001 = 1 mm

Value range y: Float32, resolution 0.001 = 1 mm

Value range z: 0, 1

Standard: - 270.000 270.000 0

Output: MW -71.000 71.000 0



LDS70A does not perform a plausibility check of the preset measurement window. It is the responsibility of the user to set the correct parameters.

Table 11: Measurement window - output behavior

| | Measurement window | | |
|--------------|-------------------------------|------------------|-------------------------------|
| | distance < x | x < distance < y | distance > y |
| z = 0 | DE02 | Measured value | DE02 |
| z = 1 | No output / blanking pulse | Measured value | No output / blanking pulse |

OF – Offset

OF parameterizes a user specific offset x which is added to measured distance value.

Query: OF
 Set: OFx
 Value range x: Float32, resolution 0.001 = 1 mm
 Standard: 0.000
 Output: OF 0.000



LDS70A does **not** perform a plausibility check of the preset offset. It is the responsibility of the user to set the correct parameters.

QA – Analogue output

QA parameterizes the analog current output. For information about the electric wiring see chapter 4.12.

Query: QA
 Set: QAx y
 Value range x: Float32, resolution 0.001 = 1 mm
 Value range y: Float32, resolution 0.001 = 1 mm
 Standard: 0.000 1.000
 Output: MW -71.000 71.000 0

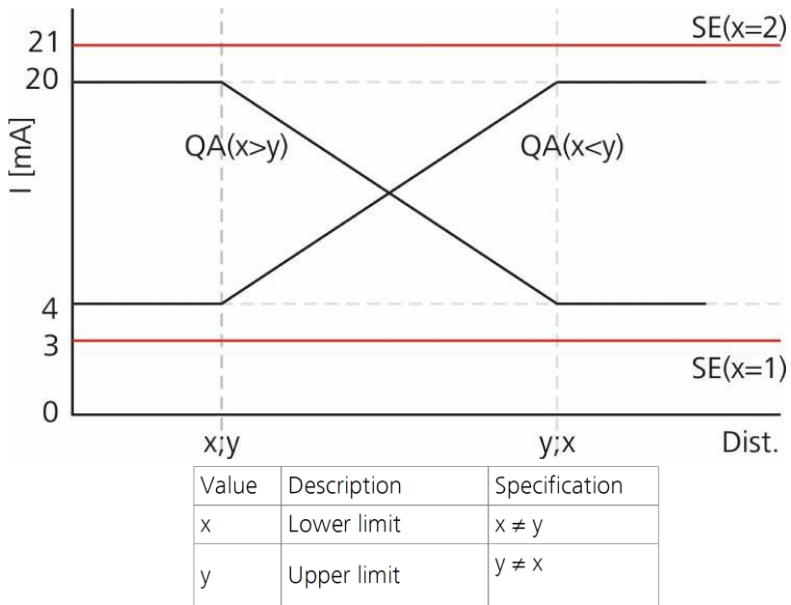

Figure 9: Analog output behaviour



The measurement window (MW) also applies to the analog output.

The output current (in mA) is calculated as follows:

$$x < y: \quad QA[mA] = 4 \text{ mA} + 16 \text{ mA} * \frac{Dist - x}{y - x}$$

$$x > y: \quad QA[mA] = 20 \text{ mA} - 16 \text{ mA} * \frac{Dist - y}{x - y}$$

Dist = measured distance



Please do not use the analog output for fast processes with high distance changes. The typical settling time for jump from 4 mA to 20 mA is 40 μ s.

Q1, Q2 – Digital output

Q1/Q2 parameterizes the behavior of the switching outputs. The parameters include the beginning w of the measuring range when the output switches, the length x of the measuring range, the hysteresis y as well as the logic behavior z .

| | |
|----------------|---|
| Query: | Q1 or Q2 |
| Set: | Q1w x y z or Q2w x y z |
| Value range w: | Switching threshold - 9999,999 ... + 9999,999 Float32; resolution 0.001 = 1 mm |
| Value range x | Switching range - 9999,999 ... + 9999,999; $x > 0$, $x > y$ Float32, resolution 0.001 = 1 mm |
| Value range y | Switching hysteresis - 9999,999 ... + 9999,999; $y \geq 0$ Float32, resolution 0.001, |
| Value range z | Switching state 0 or 1 |
| Standard: | 0.000 1.000 0.050 1 |
| Output: | Q1 0.000 1.000 0.050 1 |

Figure 10: Switching behavior of Q1 and Q2

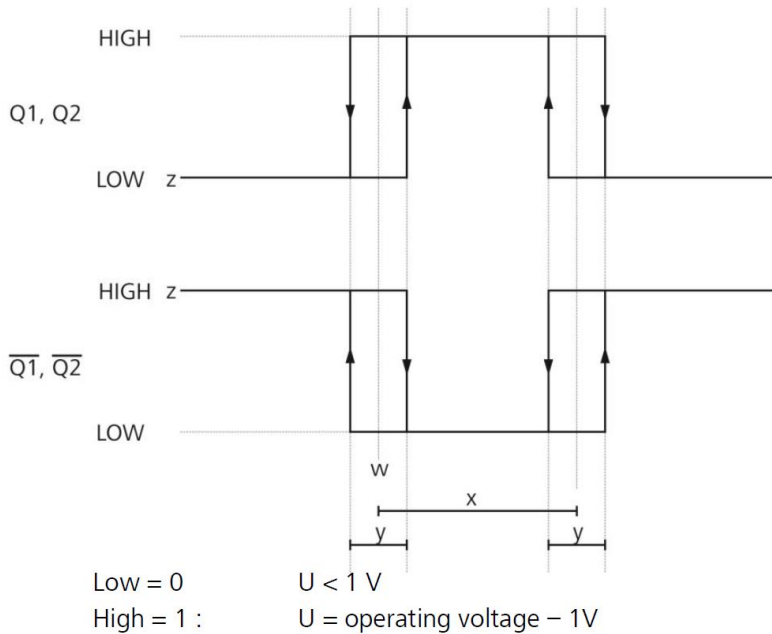

SA – Mean average

SA parameterizes the number x of the single measured values to be averaged for one measurement. SA directly correlates with the measurement frequency MF. SA and MF determine the output frequency of the measured values.

| | |
|----------------|------------------------------|
| Query: | SA |
| Set: | Sax |
| Value range x: | 32 bit integer, resolution 1 |
| Standard: | 1000 |
| Output: | SA 1000 |

The spread of the measured distance values can be reduced by calculating the mean average value.

$$\sigma_{SA} = \frac{\sigma_1}{\sqrt{SA}}$$

| | |
|---------------|--|
| σ_{SA} | Spread after mean value determination from several distance measurements |
| σ_1 | Spread of single measured value (± 60 mm) |
| SA | Mean value |

Example:

| Measurement frequency MF (Hz) | Mean value SA | Output frequency (Hz) | Spread (mm) |
|-------------------------------|---------------|-----------------------|-------------|
| 15000 | 1 | 15000 | ± 60 |
| 15000 | 10 | 1500 | ± 19 |
| 15000 | 100 | 150 | ± 6 |
| 15000 | 1000 | 15 | ± 2 |

Table 12: Mean value outcome

For table above applies:

Measuring frequency 15 kHz and output frequency 15 kHz will be achieved with baud rate = 921.600 and binary output.



All valid measured distance values will be used for SA. If a distance value is out of the measurement window MW it will be ignored for the SA calculation.

SO – Set offset

SO carries out a single distance measurement and sets it as - OF (offset). SO can only be executed and is not really a parameter. SO can be used for zero adjustment of distances in systems or processes.



Please note the interaction of parameter MW, OF, SO.

SD – Serial data format

SD parameterizes the output format of the serial data output. The user may select the output data encoding as well as the transmitted values.

Query: SD
 Set: SDn m
 Value range n: 0, 1, 2
 Value range m: 0, 1, 2, 3
 Standard: 0 0
 Output: SD 0 0

Table 13: Parameter SD - Output encoding

| n | Output encoding |
|----------|------------------------|
| 0 | decimal |
| 1 | Not available |
| 2 | Binary |

| m | Output values |
|----------|---|
| 0 | Distance |
| 1 | Distance + signal quality |
| 2 | Distance + temperature |
| 3 | Distance + signal quality + temperature |

Explanation binary output format

Distance value:

2 Byte, MSB = Bit 7

MSB of Byte 1 is always 1

MSB of Byte 0 is always 0

Measurement data = Bit 6 ... Bit 0 of each Byte

Coding: Two's compliment

Scaling factor from binary to decimal values: *1/100

| | Byte 1 Distance | | | | | | | | Byte 0 Distance | | | | | | | |
|------|-----------------|---|---|---|---|---|---|---|-----------------|---|---|---|---|---|---|---|
| Bit | 7 | 6 | 5 | 4 | 3 | 2 | 1 | 0 | 7 | 6 | 5 | 4 | 3 | 2 | 1 | 0 |
| Data | 1 | x | x | x | x | x | x | x | 0 | x | x | x | x | x | x | x |

Signal strength:

1 Byte

MSB = Bit 7

MSB of Byte 0 is always 0

Measurement Data = Bit 6 ... Bit 0

Scaling factor from binary to decimal values: *2

| | Byte 0 Signal | | | | | | |
|------|---------------|---|---|---|---|---|---|
| Bit | 7 | 6 | 5 | 4 | 3 | 2 | 1 |
| Data | 0 | x | x | x | x | x | x |

Temperature:

1 Byte

MSB = Bit 7

MSB of Byte 0 is always 0

Measurement Data = Bit 6 ... Bit 0

Conversion from binary to decimal values: -40

| | Byte 0 Temperature | | | | | | |
|------|--------------------|---|---|---|---|---|---|
| Bit | 7 | 6 | 5 | 4 | 3 | 2 | 1 |
| Data | 0 | x | x | x | x | x | x |

Example:

| | | | | | | | | | | | | | | | | | |
|-------------|---------------------------------|---|---|---|---|---|---|---|--------------|--|--|--|--|--|--|--|------------|
| Distance | 1 0 0 0 0 0 1 0 0 1 0 1 0 0 1 0 | | | | | | | | :100 = 3,38m | | | | | | | | |
| Signal | 0 | 0 | 0 | 0 | 1 | 0 | 1 | 1 | | | | | | | | | *2 = 22 |
| Temperature | 0 | 1 | 0 | 1 | 1 | 1 | 0 | 1 | | | | | | | | | -40 = 53°C |

SE – Error mode

Parameterizes the behavior of switching outputs Q1 and Q2 and of analogue output QA in case of faulty measurements as well as the state after carrying out a single distance measurement.

Query: SE
 Set: Sen
 Value range n: 0, 1, 2
 Standard: 1
 Output: SE 1

Table 14: Output behavior on error

| n | Q1, Q2 (z=0) | Q1, Q2 (z=1) | QA |
|---|--------------|--------------|------------|
| 0 | Last value | Last value | Last value |
| 1 | High | Low | 3 mA |
| 2 | Low | High | 21 mA |

Low: $U < 1 \text{ V}$

High: $U = \text{operating voltage} - 1 \text{ V}$

The LDS70A does not perform a plausibility check of the preset error mode.

ST – Select Target

ST defines the target which should be detected. LDS70A is able to detect 4 different targets in maximum. Selection will be done between the first or the last detected target.

first target – target next to the LDS70A

last target – last detected target

Output will be the distance of the defined target.

Query: ST
Set: STx
Value range x: 0 (first target) or 1 (last target)
Standard: 0
Output: ST 0



Parameter MW (measuring window) and SA (mean value, average) will influence the output. If the selected target will be outside of the range of measurement window the output will be not a distance value – see setting of MW, parameter z

TC – Time for calibration

Parameterizes the time between 2 customized calibrations.

The calibration is necessary to stabilize the distance accuracy and to avoid a lower accuracy because of temperature changes in the environmental of the electronic parts.

| | |
|----------------|--|
| Query: | TC |
| Set: | TCx |
| Value range x: | 0 (no calibration), 1 ... 3660 s (= 1 s to 1 h interval) |
| Standard: | 1 |
| Output: | TC 1 |

Up to a Measuring frequency of approx. 35 kHz the calibration will be done without any influences of the output frequency.

Between 35 kHz and 40 kHz it could be possible that the data output will interrupt for one (1) distance output every x seconds (x= parameter of TC).

TE – Terminator

Sets the termination char for the output of measured values in ASCII format. (see also command SD).

| | |
|----------------|---------|
| Query: | TE |
| Set: | TEx |
| Value range x: | 0 ... 9 |
| Standard: | 0 |
| Output: | TE 0 |

Table 15: Available termination chars

| X | ASCII-Hex | Meaning |
|----------|------------------|----------------|
| 0 | 0x0D 0x0A | CR LF |
| 1 | 0x0D | CR |
| 2 | 0x0A | LF |
| 3 | 0x02 | STX |
| 4 | 0x03 | ETX |
| 5 | 0x09 | HTab |
| 6 | 0x20 | Space |
| 7 | 0x2C | Single quote |
| 8 | 0x3A | Colon |
| 9 | 0x3B | Semicolon |

Invalid characters will be ignored. The previously selected terminator will be maintained.

Trigger setup – general information

The LDS70A Trigger may be used as input or output. There are three possible scenarios:

1. Trigger input – externally initiated measurement

External trigger signal will be sent to LDS70A to start a single measurement like DM in accordance with parameter TI.

2. Trigger output - connection between two devices:

The output trigger signal of the 1. LDS70A (parameterized with TO) starts a single measurement DM of the second LDS70A (parameterized with TO).

3. Continuous distance tracking controlled by trigger

Differences between trigger input and trigger output:

Important is the parameter y of TI and TO.

TI $y > 0$ / TO $y = 0$

Trigger input

The measurement starts after an external trigger impulse.

TI $y = 0$ / TO $y > 0$

Trigger output

LDS70A sends a trigger impulse to the second device.

The parametrization of the trigger connection is carried out via the serial interface.



For the trigger function either TI **or** TO must be activated only.
A concurrent use of TI and TO is not possible.

TI – Trigger setup input

The parameterization of trigger input will be set by the command TI.

| | | |
|---|-------|--|
| x | edge | Sets the sensitive edge of the trigger signal and controls start and stop for Autotrigger function |
| | | 0 rising edge (low-high) |
| | | 1 falling edge (high-low) |
| | | 2 both rising and falling edge |
| | | 3 start/stop Autotrigger with rising edge |
| | | 4 start/stop Autotrigger with falling edge |
| y | delay | Sets the time delay between trigger event and start of measurement in microseconds |

Query: TI

Set: TI x y

Value range x: 0, 1, 2, 3, 4

Value range y 0 to max 60.000 ms (1 minute)

active: from 1 ms upwards

disabled: 0 ms

Standard: 0 0

Output: Trigger (input) [TI]: 0, 0

Autotrigger function

The LDS70A provides a so called Autotrigger function. This function uses the trigger input signal to control the operating mode which is selected by the Autostart command (AS). The first trigger event starts the execution of the AS command. The next trigger input event will stop this process. The Autotrigger function is parameterized by the command TI (trigger input).

Example:

```
AS DT
TI 3 10
```

The continuous distance tracking (DT) starts with the first rising edge of the trigger input signal. The delay between the trigger event and start of measurement is 10 ms. The next rising edge of the trigger input signal will stop the continuous distance tracking. There is also a delay of 10 ms between trigger event and stop of measurement.

TO – Trigger setup output

The parameterization of trigger output will be set with command TO.

```
Query:      TO
Set:        TO x
Value range x: 0, 1, 2, 3
              Sets the sensitive edge of the trigger signal
              0      rising edge (low-high)
              1      falling edge (high-low)
              2      both rising and falling edge
Standard    0
Output      Trigger (output) [TO]: 0
```

Maximum frequency of Trigger OUT (TO) = MF (Measurement frequency)

UB – Unit for binary output

UB parameterizes the resolution for distance values in binary output format. This parameter influences all measurement outputs in binary format independent from the measurement frequency. UB is given in millimeters. The binary output is selected by the command SD.

| | |
|----------------|---------------------------|
| Query: | UB |
| Set: | UBx |
| Value range x: | float32; resolution 0.001 |
| Standard | 1000.000 = 1 m per digit |
| Output | UB 1.000 |

Example:

| | |
|----------|----------------------|
| UB 0.001 | resolution 1 μ m |
| UB 1.000 | resolution 1 mm |
| UB 1000 | resolution 1 m |

The measuring range will be depicted with 14 signed bits.

Distance value (binary) = Distance (mm) / UB

Value range (binary): $-8192 < \text{Distance} < 8191$



If the distance value is below or above the distance range, the binary output is 0!

6 Error processing

In case of one or more detected errors, the error code with the highest value will be transmitted (most serious defect/error).

Example:

no distance value identified, no other error: DE02

no distance value identified, in addition temperature out of range:
DE06

Non-critical errors will be reset automatically, a critical error requires a device reset (see table) – command DR or power off/ on.

Hardware errors generate error code DE04.

Table 16: Error codes

| Error code | Description | Reset |
|------------|--|---|
| DE02 | No distance identified | Automatically, with the next measured distance |
| DE04 | Device error (hardware) | Not automatically, device reset necessary |
| DE06 | Temperature out of range | Automatically, if temperature returned to specified range |
| DE10 | Internal laser voltage lower than the defined minimum voltage (ULaser _{MIN}) | Not automatically, device reset necessary |

In binary format all errors will be sent as “0” (00). The described error codes will be outputted, if an error is detected during

- LDS70A measurement (DM, DT)
- a measuring mode (DM, DT) will be started.

Output of error message (like output of measuring values):

- once for measuring mode DM
- in the specified output frequency for measuring mode DT

The measuring mode DT can be stopped with <ESC> in the case of error and error message output too.

The communication with LDS70A, e.g. parameterizing, reset or start of new measurement, will be not influence by the error message.

If DT is started and the error did not reset automatically, the error message will be outputted again.



The temperature (check with command TP) may be higher than the ambient temperature. Approx. 30 min. after power ON the measured temperature could be higher than ambient temperature.

7 Accessories

There are several accessories available for the LDS70A.

Table 17: Common accessories

| Part No. | Name | Description |
|------------|-----------|-------------------------------------|
| 15-2006-26 | CCS30A-02 | Connection cable, 12 pin, 2 m |
| 15-2006-02 | CCS30A-05 | Connection cable, 12 pin, 5 m |
| 15-2006-03 | CCS30A-10 | Connection cable, 12 pin, 10 m |
| 15-2001-00 | SDCO232-2 | RS232 programming cable, 2 m |
| 12-2019-02 | JWS | Mounting and adjustment bracket |
| 12-2043-00 | PT70A-30 | Dust and sun protection tube, 30 mm |

Other cable length or additional accessories are available on request.

8 EG Declaration of conformity



We herewith declare, represented by the signatories, that the following designated product

Laser distance sensor

LDS70A

agrees with the following directives:

2014/30/EU Directive of Electromagnetic Compatibility

2011/65/EU RoHS Directive

The following harmonized standards were considered:

EN 61326-1:2013 Electrical equipment for measurement, control and
(IEC 61326-1:2012) laboratory use, EMC requirements Part1: General
requirement

EN 50581:2012 Technical documentation for the assessment of
electrical and electronic products with respect to the
restriction of hazardous substances

The following additional standards/specifications were considered:

EN 60825-1:2014 Safety of Laser products - Part 1: Equipment
(IEC 60825-1:2014) classification, requirements and user guide
Laser Class 1

Rostock, November 1st 2019

ASTECH Angewandte Sensortechnik GmbH

A handwritten signature in blue ink, appearing to read 'J. Mirow', is located below the company name.

Jens Mirow
Managing Director